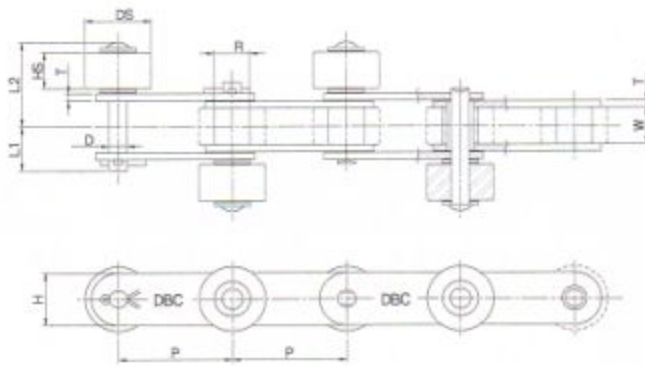
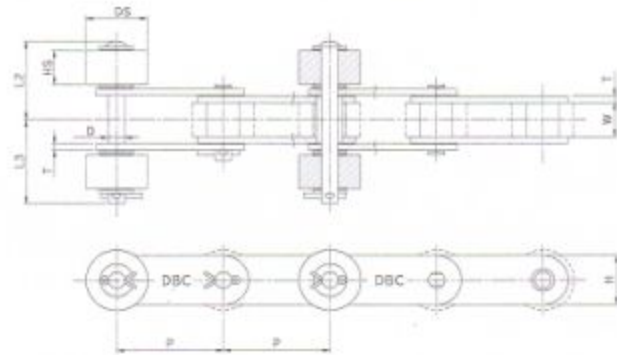

## Double Pitch Type 双节距型

**Z - Type**

**K - Type**

DONG BO Chain No.		Pitch	Inner width	Roller Dia		Plate		Pin			Side Roller		Approx Weight			
Basic Chain No	Type of side roller			P	W <sub>min</sub>	S	R	T	H	D	L1	L2	L3	DS	HS	A*
<b>DBC 2040*</b>	<b>SSR</b>	25.40	7.95	7.92	-	1.5	12.0	3.97	9.65	18.9	18.2	15.88	7.8	0.7	1.1	0.9
<b>DBC 2042*</b>	<b>PSR</b>	25.40	7.95	-	15.88	1.5	12.0	3.97	9.65	18.9	18.2	15.88	7.8	0.7	1.1	0.9
<b>DBC 2050</b>	<b>SSR</b>	31.75	9.53	10.16	-	2.0	15.0	5.09	11.9	22.5	23.2	19.05	9.4	1.1	1.6	1.3
	<b>PSR</b>	31.75	9.53	-	19.05	2.0	15.0	5.09	11.9	22.5	23.2	19.05	9.4	1.1	1.6	1.3
<b>2052DBC</b>	<b>SSR</b>	38.10	12.70	11.91	-	3.2	18.1	5.96	16.95	30.9	32.70	22.23	12.6	1.8	2.6	2.0
<b>2060DBC</b>	<b>PSR</b>	38.10	12.70	-	22.23	3.2	18.1	5.96	16.95	30.9	32.70	22.23	12.6	1.8	2.6	2.0
<b>2062DBC</b>	<b>SSR</b>	50.80	15.88	15.88	-	4.0	24.1	7.93	20.95	36.95	42.35	28.58	15.8	3.2	4.3	-
<b>2080DBC</b>	<b>PSR</b>	50.80	15.88	-	28.58	4.0	24.1	7.93	20.95	36.95	42.35	28.58	15.8	3.2	4.3	-
<b>2082DBC</b>	<b>SSR</b>	63.50	19.05	19.05	-	4.8	30.1	9.54	24.5	44.20	47.3	39.69	19	4.8	7.0	-
<b>2100DBC</b>	<b>PSR</b>	63.50	19.05	-	39.69	4.8	30.1	9.54	24.5	44.20	47.3	39.69	19	4.8	7.0	-

\* 2040~ = standard 'S' -Roller Type, 2042~ = oversize 'R'-Roller Type

\* A = steel roller chain with plastic side roller

\* B = steel roller chain with steel side roller

\* C = plastic roller chain with plastic side roller

\* 2040~ = 标准型 "S" 型滚子, 2042~ = 大滚子型 "R" 型滚子

\* A = 钢制中心滚子附加塑料侧滚子型

\* B = 钢制中心滚子附加钢制侧滚子型

\* C = 塑料中心滚子附加塑料侧滚子型

Note) 1. Plastic Side Roller Chain (R-Roller Type) are available in size 2040, 2050 and 2060

2. Weights are listed for Z-type at every link and K-type at every 2nd link.

注) 1. 塑料侧滚子适用于2040, 2050和2060

2. 每一节Z型和每两节K型的质量已列明

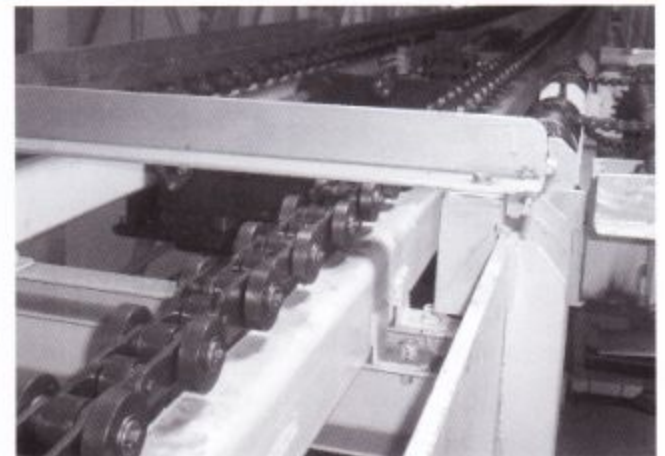



## Side Roller Chains

### 侧滚子链条

#### G-Hole Installation Type G孔安装型

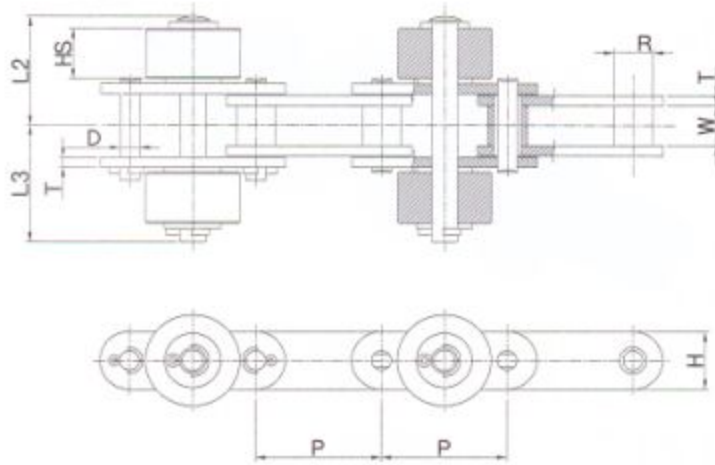

unit : mm

DONG BO Chain No.	Pitch P	Inner Width W	R-Roller R	Plate		Pin			Side Roller		Approx Weight (kg/m)	
				T	H	D	L2	L3	DS	HS	PSR*	SSR*
DBC 2040 PSR -GK	25.4	7.95	7.92	1.5	12	3.97	18.9	18.2	15.88	7.8	0.8	1.3
DBC 2050 PSR -GK	31.75	9.53	10.16	2	15	5.09	22.5	23.2	19.05	9.4	1.3	1.8
DBC 2060 PSR -GK	38.10	12.7	11.91	3.2	18.1	5.96	30.9	32.7	22.23	12.6	2	2.8
DBC 2080 PSR -GK	50.8	15.88	15.88	4	24.1	7.93	36.95	42.35	28.58	15.8	3.5	4.7

\*PSR=Plastic Side Roller / SSR=Steel Side Roller  
PSR=塑料侧滚子 SSR=钢制侧滚子

#### Guide Plate Type for Derailing Prevention

##### 防脱离导向型

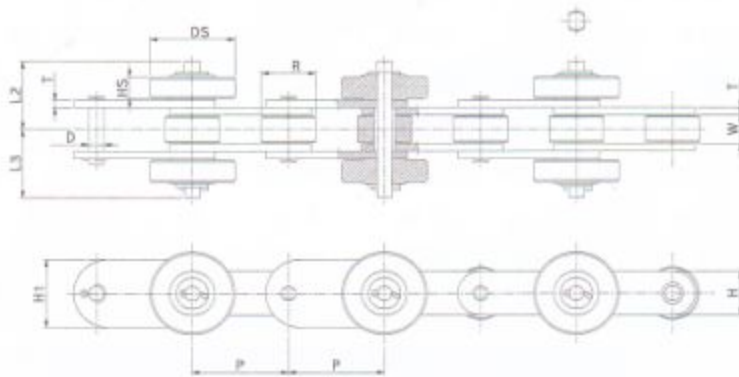

unit : mm

DONG BO Chain No.	Pitch P	Inner Width W	Roller Dia R	Plate			Pin			Side Roller		Approx Weight (kg/m)
				T	H	H1	D	L2	L3	DS	HS	
DBC 2080 SSR-TG	50.8	15.88	28.58	4	24.1	34	7.94	36.95	36.95	38.1	12.0	6.1
						37				45.0		
DBC 2100 SSR-TG	63.5	19.05	39.69	4.5	30.1	48	9.54	38.7	41.8	57.2	12.0	10.6
						60.0						

Note) When ordering, please indicate installation method (inner or outer plate installation) and spacing of guide plate.  
注: 订货时, 请说明滚子安装方法 (内板或外板安装) 和GUIDE板连接。