

ROD ENDS

무급유형, mm치수, 암나사
 MAINTENANCE-FREE
 METRIC DIMENSION
 FEMALE THREAD

STAINLESS STEEL



JFTS

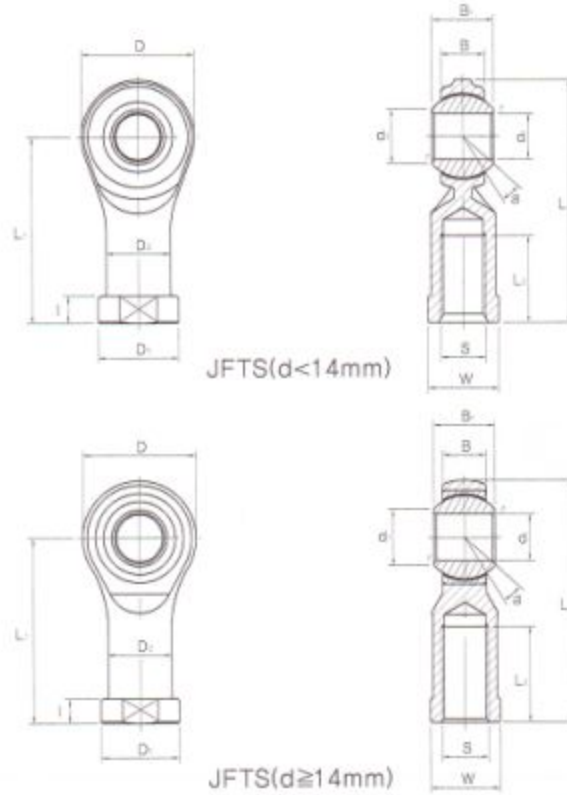

JFTS(d<14mm)

JFTS(d≥14mm)

호칭번호 (Bearing No.)	질량 (Mass) gr.	주요 치수 (Dimensions) mm														요동각도 (Tilting angle) a°	볼 직경 (Spherical Diameter) mm	정부하용량 (Basic Static Load Ratings) Co Kg
		d	나사 (Threads) KS 2급/S	D	B +0.1 -0.4	B1 +0 -0.1	d1	L (max)	I	L1 (max)	L2	W +0 -0.2	D1	D2	r			
JFTS 3	6.5	3	M 3×0.5	12	4.5	6	7.4	27	3	21	9.5	7	8	6.5	0.5	11	9.525	300
JFTS 4	10	4	M 4×0.7	14	5	7	7.5	31	4	24	12	8	9.5	8	0.5	12	10	350
JFTS 5	16.5	5	M 5×0.8	16	6	8	7.7	35	4	27	13.5	9	11	9	0.5	13	11.1	400
JFTS 6	25	6	M 6×1.0	18	6.75	9	9	39	5	30	14	11	13	10	0.5	13	12.7	510
JFTS 8	43	8	M 8×1.25	24	9	12	10.4	48	5	36	15	14	16	13	0.5	13	15.87	760
JFTS 10	72	10	*M10×1.25 M10×1.5	26	10.5	14	12.9	56	7	42.5	20	17	19	15	0.5	13	20.6	960
JFTS 12	107	12	M12×1.75	31	12	16	15.8	66	7.5	50.5	23	19	22	17.5	0.5	13	22.5	1,120
JFTS 14	160	14	*M14×1.5 M14×2.0	35	13.5	19	16.9	75	8.5	57.5	25	22	25	20	0.5	15	25.4	1,550
JFTS 16	210	16	*M16×1.5 M16×2.0	39	15	21	19.3	83	8.5	63.5	30	24	27	22	0.5	15	28.5	2,060
JFTS 18	295	18	M18×1.5	43	16.2	23	21.7	92	10	71.5	33	27	31	25	0.5	15	31.6	2,570
JFTS 20	380	20	M20×1.5	48	18	25	23.8	101	11	78	38	30	34	27.5	0.5	15	34.5	2,840
JFTS 22	490	22	M22×1.5	54	20	28	25.8	111	12	84	43	32	37	30	0.5	15	38.1	3,400
JFTS 25	750	25	M24×2.0	64	22	31	29.8	126	12	94	49	36	42	33.5	0.5	15	43	5,980
JFTS 30	900	30	M30×2.0	73	25	37	34.8	145	16.5	108.5	50	47	49	40	0.5	15	50.8	7,600

주문안내 : 위표의 나사에 별표가 있는 것은 주문시 나사치수를 명기해 주시기 바랍니다.

Please denote thread dimension in order sheet when you order star marked threaded rod ends in upper table.

초기사용 : 무윤활로서 사용이 가능하지만 초기 윤활을 할 경우에는 구면부에 오일 또는 그리스를 도포하기 바랍니다.

This model can be used without lubrication. However, if desiring to provide initial lubrication, apply oil or grease to the spherical area.