

## Case Conveyor Chain

### 锻造输送链条

The case conveyor rotates a chain inside a casing with square sections.

The chain has the most logical shape according to the type of the conveyor and the characteristics of conveyed items. There are T and U-types and special UA, UB and UC-types. This chain maintains sufficient strength through our unique heat processing technique, is light, has high density, and is adequate for harsh conditions.

根据输送物体性质不同，链条有不同的形状。主要有T型、U型。特殊的UA型、UB型，经我公司特殊的热处理工艺，该种链条有足够的硬度与强度适用于各种恶劣的环境。

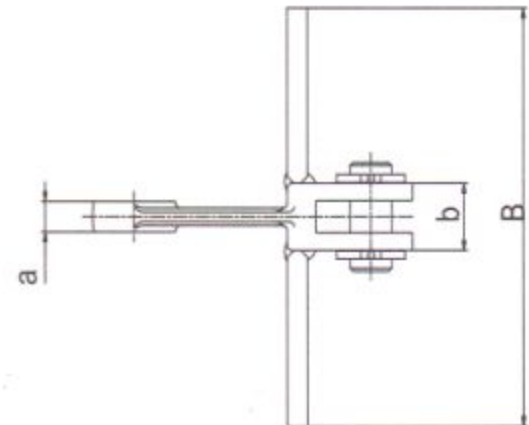
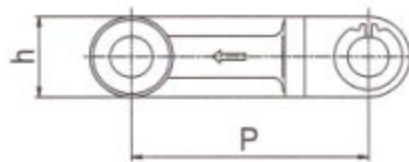

### Forging type 锻造型

unit : mm

DONG BO Chain No.	Pitch P	Dimensions of Link				Dimensions of Att. + B	Avg. Breaking Load (kgf)	Max. Allowable Load (kgf)	Weight of Chain (kg/m)
		a	b	h	l				
DBC F05125	120	10	21	26	6	125	5,000	830	3.30
DBC F05150	120	10	21	26	6	150	5,000	830	3.33
DBC F05190	120	10	21	26	6	190	5,000	830	3.40
DBC F309	142	19	42	50	11	270	30,000	3.340	
DBC F40	142	25	56	50	17	450	43,000	5.100	
DBC F363	142	29	62	50	16	480	48,000	6.600	
DBC F10125	150	15	32	34	8	125	10,000	1.670	4.60
DBC F10150	150	15	32	34	8	150	10,000	1.670	4.86
DBC F10190	150	15	32	34	8	190	10,000	1.670	6.05
DBC F10240	150	15	32	34	8	240	10,000	1.670	8.80
DBC F10290	150	15	32	34	8	290	10,000	1.670	8.85
DBC F10340	150	15	32	34	8	340	10,000	1.670	9.84
DBC F15290	150	18	37	40	10	290	20,000	2.500	11.63
DBC F20340	150	20	41	46	11	340	30,000	3.340	15.9
DBC F20410	150	20	41	46	11	410	30,000	3.340	21.2
DBC F30410	200	20	41	46	12	410	40,000	5.000	17.3
DBC F30480	200	20	41	46	12	480	40,000	5.000	19.1
DBC F40480	200	22	45	52	12	480	48,000	6.600	22.4
DBC F40570	200	22	45	52	12	570	48,000	6.600	25.2
DBC F50570	200	26	54	54	14	570	58,000	8.300	27.5

\* Att = Attachment      \* Att = 附件